

SECTION A-A

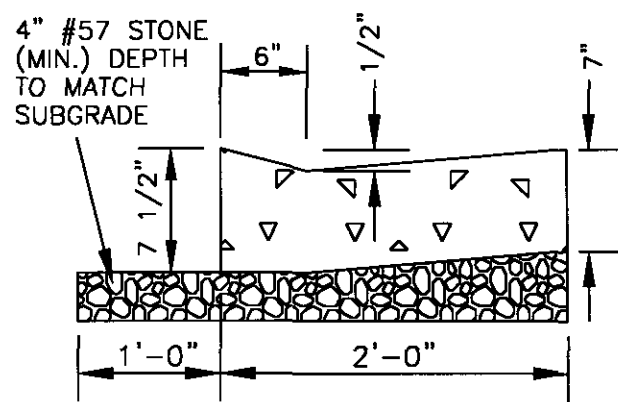

SECTION B-B

CONCRETE APRONS ARE REQUIRED IF:

1. THERE IS AN EXISTING SIDEWALK ADJACENT TO THE DRIVEWAY.
2. THERE IS A CURB INLET WITHIN 25' OF THE ENTRANCE.
3. THE LOT ADJACENT TO THE DRIVEWAY IS LOWER THAN THE CURB.
4. SEE APRON STANDARD

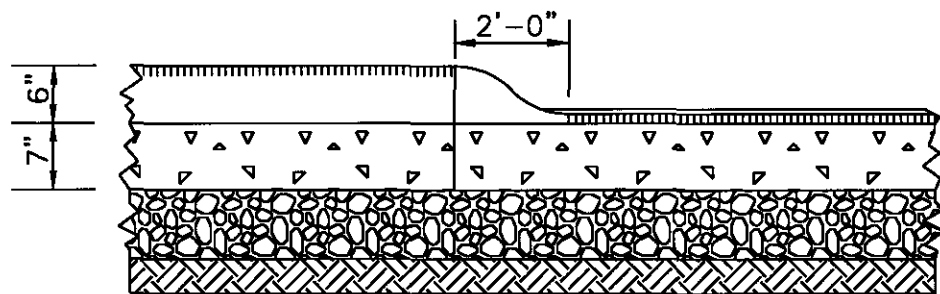

SECTION ELEVATION @ GUTTER LINE

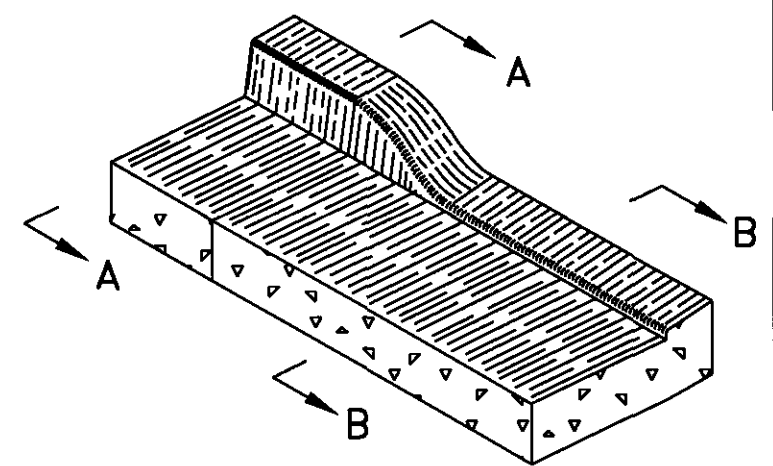

ISOMETRIC VIEW

NOTE: WHEN A CURB CUT IS INSTALLED IN EXISTING CURB & GUTTER, THE EXISTING CURB & GUTTER SHALL BE COMPLETELY REMOVED (INCLUDING THE GUTTER PAN) BETWEEN EXISTING JOINTS AND A COMPLETE CURB CUT SECTION INSTALLED. IN LIEU OF REMOVING THE EXISTING CURB & GUTTER BETWEEN JOINTS, THE EXISTING CURB & GUTTER MAY BE SAWCUT PROVIDED THAT THE REMAINING SECTIONS ARE 5' OR GREATER IN LENGTH.

RESIDENTIAL CURB CUT FOR DRIVEWAYS

County of Henrico
Department of Public Works

JANUARY 1, 2002

CURB-CUT.DWG

